

BROAD HEAT METER

MODEL SELECTION & DESIGN MANUAL



■ Functions

- Measure and real time display instantaneous cooling/heating consumption, flow, temperature, accumulative cooling/heating consumption and flow of water systems.
- Cooling/heating piping, building, household metering as charging basis.
- LCD display, micro power consumption design, built-in lithium battery which can be used for 6 years without any external power.
- Outfit IC card controller to actualize pre-pay management (optional).
- Outfit RS485 communication interface, support M-bus communication protocol and actualize wired or wireless remote transmission optional.
- Wireless module can actualize wireless collection (optional).

■ Applications

- Widely applicable for cooling/heating supply household metering.
- Applicable for cooling/heating metering in piping network.
- Applicable for hot water and other liquid cooling/heating metering.
- Applicable for water flow measurement.

■ Features

- Very competitive prices: only 20%~40% of those for similar products in Europe and America. The reason why prices are so competitive is because of BROAD's super R&D capability, the other reason is because of BROAD's vision to advocate "behavioral energy saving" .
- Use ultrasonic flowmeter to measure the flow: it has very high accuracy and the measurement is stable and reliable. It has no mechanically rotating part and it is not easily damaged.
- Use PT1000 platinum resistance temperature sensor: the temperature measurement is precise.

Working Principles

BROAD heat meter consists of three parts: ultrasonic flow sensor, temperature sensor and calculator.

Ultrasonic flow sensor:

The liquid flow speed directly affects the transmission time of sound waves in the liquid. The transmission time is shorter in downstream direction and longer in upstream direction of the current. The time difference reflects the flow speed of the liquid. If the time difference is big, the flow speed is fast; when the time difference is small, the flow speed is slow. According to the flow speed and the section area of the pipe, we can calculate the flow.

Temperature sensor:

The temperature sensors are installed on water supply/return water pipe respectively to measure the temperature of supply/ return water of the heat exchanging system. Those 2 sensors are well paired and used to measure the temperature (the matching precision is higher than 0.1°C).

Calculator:

According to flow rate, temperature difference and the coefficient K of the corresponding temperature, the cooling/heating consumption can be worked out. The calculation formula as follows:

Cooling/heating consumption = Flow (m³/h) x Differential temperature (°C) x Coefficient K.

BROAD heat meter is designed according to the China National Urban Construction Industry Standards for Heat Meter (CJ128-2000), and manufactured under the License for Manufacturing Measuring Instruments in china. It complies with the European Standard(EN1434) and the International Standard(01ML-R75) for heat meter.

Nomenclature

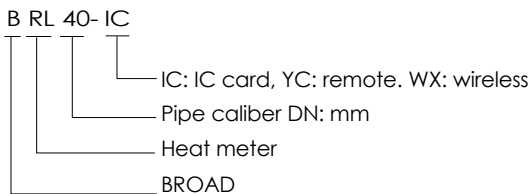

BRL15 ~ BRL40

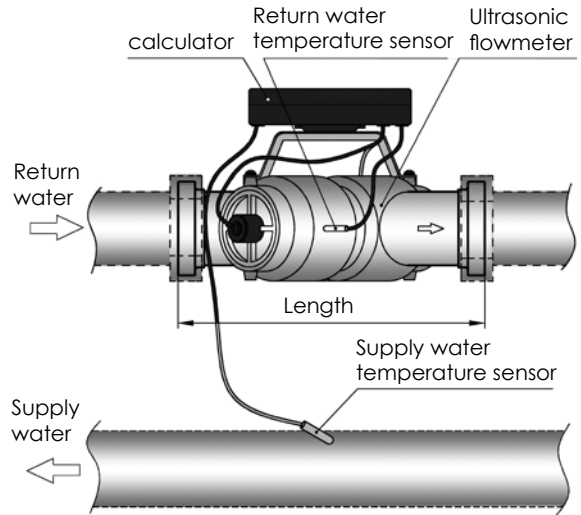

BRL50 ~ BRL500

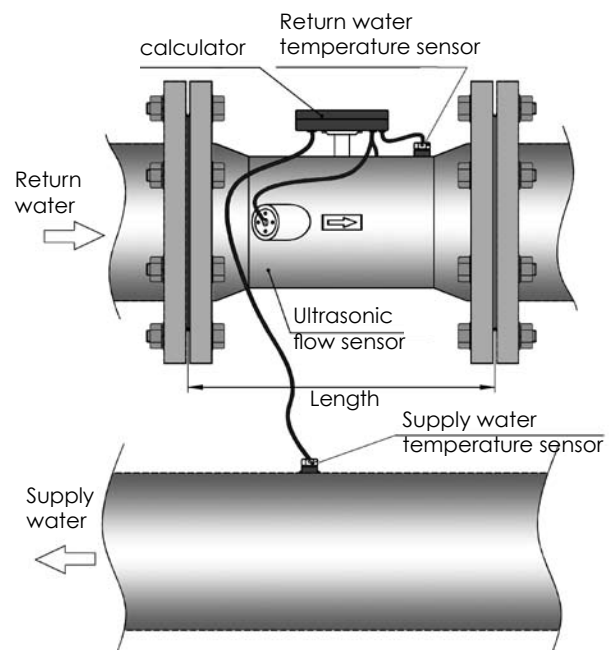

Technical Characteristics

Technical specifications

No.	Name	Items	Specifications
1	Ultrasonic flow sensor	Precision	Grade 3.0 (BRL 15~40) Grade 2.0 (BRL50~500)
2		Working temperature	4~95°C
3		Working pressure	1.6MPa (BRL15~40) 1.0MPa /1.6 MPa (BRL50~500), optional
4		Pressure loss	BRL15~40: <20kPa. BRL50~500, 0kPa
5		Measurement Range ratio	1:100
6	Temperature sensor	Type	PT1000
7		Matching precision	0.1°C
8		Temperature range	0~105°C
9		Cable length	1.5m (BRL15~80). 2.5m (BRL100~500)
10	Calculator	Temperature sensitivity	0.01°C
11		Differential temperature	3~60°C
12		Sampling interval	0.25s
13	Other	Ambient temperature	Indoor 5~55°C (grade A)
14		Protection grade	IP67
15		Data protection	All data are saved in E2PROM. The data can be saved for 10 years after system power off.
16		Battery	Voltage: 3.6V. Life: 6 years



BRL15 ~ BRL40



BRL50 ~ BRL500

Pressure loss curves

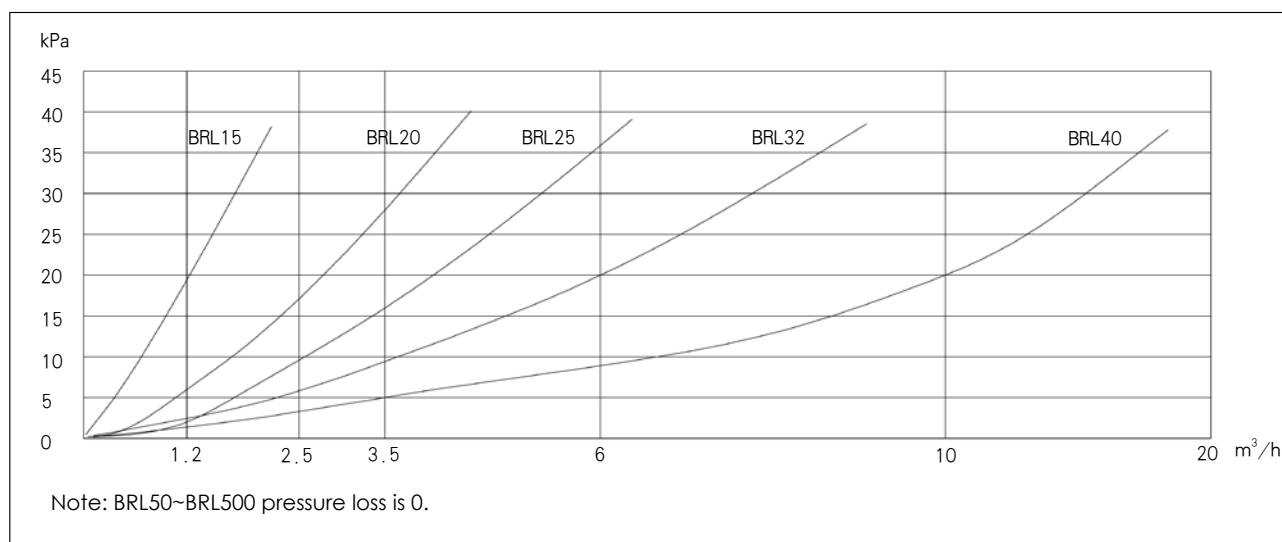

Parameters & Prices

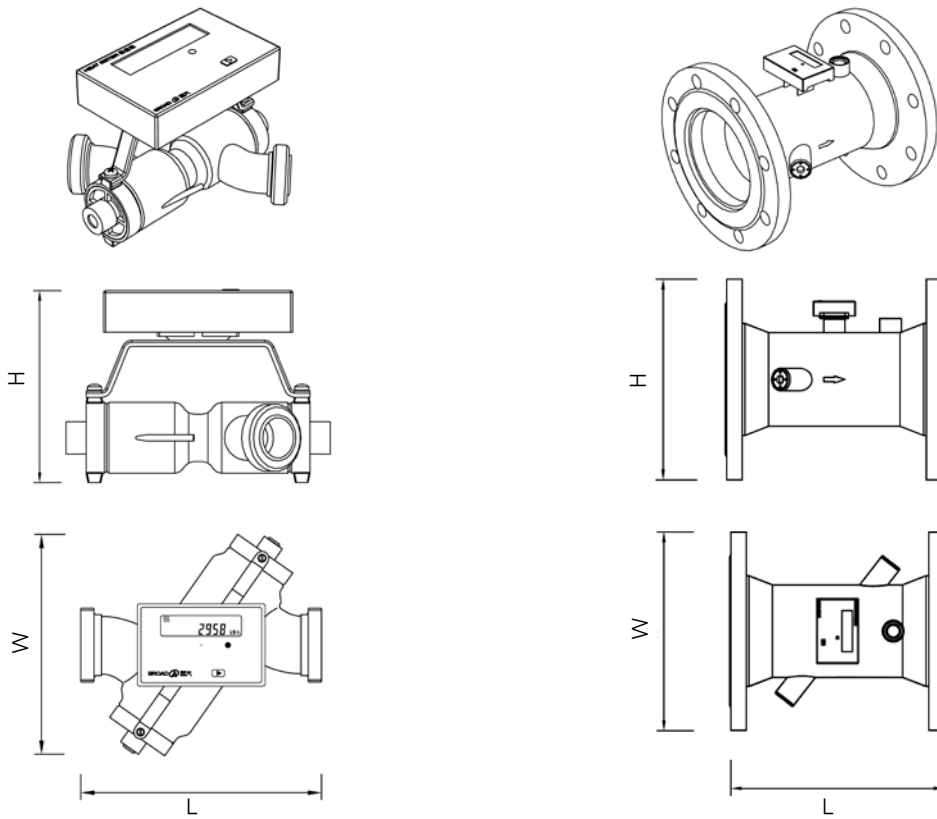

No.	Model	Price (Euro)	Applicable flow rate(m ³ /h)			Dimension (mm)			Weight (kg)	Pipe caliber DN(mm)	Tie-in
			Normal	Min.	Max.	L	W	H			
1	BRL15	73	1.5	0.03	3.0	122	148	70	0.35	15	G ³ / ₄ B pipe thread
2	BRL20	81	2.5	0.05	5.0	122	148	75	0.40	20	G 1 B pipe thread
3	BRL25	116	3.5	0.07	7	140	167	85	0.55	25	G 1 ¹ / ₄ B pipe thread
4	BRL32	160	6	0.12	12	157	187	90	0.70	32	G 1 ¹ / ₂ B pipe thread
5	BRL40	275	10	0.2	20	171	201	95	0.90	40	G 2 B pipe thread
6	BRL50	475	15	0.3	30	295	125	140	5.8	50	Standard flange (PN10, PN16, optional)
7	BRL65	723	25	0.5	50	295	145	156	6.8	65	
8	BRL80	796	40	0.8	80	295	160	173	7.6	80	
9	BRL100	877	60	1.2	120	331	220	220	13.2	100	
10	BRL125	960	100	2.0	200	305	250	250	16.5	125	
11	BRL150	1056	150	3.0	300	310	285	285	19.1	150	
12	BRL200	1218	250	5.0	500	330	340	340	34.6	200	
13	BRL250	2437	400	8.0	800	360	405	405	44.2	250	
14	BRL300	3006	600	12	1200	430	460	460	58.7	300	
15	BRL350	3542	750	15	1500	480	520	520	84.8	350	
16	BRL400	3981	900	18	1800	530	580	580	111.1	400	
17	BRL450	4680	1200	24	2400	530	640	640	162	450	
18	BRL500	5963	1500	30	3000	590	715	716	192	500	

Note:

- Applicable flow rate means the best flow rate range that customer can use as reference for the model selection. The flow rate measurement range is much wider than the applicable flow rate. The heat meter can measure the flow rate directly. It can be used as a ultrasonic flowmeter, to be separately ordered.
- The above mentioned ex-works prices are valid till Dec. 31, 2008.

Installation Guide

Notice

- The general principle for installation: the meter pipe must always be full of the medium, and make sure the medium liquid's flow is stable.
- Carefully consider the installation location and other requirements during system design phase, so as to facilitate the later installation and the future usage and maintenance management, and also enhance the reliability and the precision.
- The installation location should avoid exposure to sunshine, flood, freezing and contamination.
- Cleaning the pipe before installation, in order to avoid the welding debris, humps and sands inside of pipe.
- The heat meter should be installed on the return water pipe, make sure arrow direction on the meter is in the same direction with the liquid flow direction. The straight pipe sections in front and behind the heat meter should follow the requirements: the front end straight pipe length of the heat meter should be over $6D$ and the rear end should be over $3D$ (D is the caliber of heat meter connection pipe).

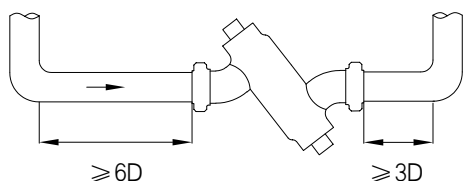

- The flow sensor should be installed as far as possible away from the valve, three-way pipe, elbow, water pump and filter.
- The flow sensor can not be installed at the suction side of the pump, top of the pipe or the vertical pipe segment with free outlet.
- During the installation of flow sensor, please keep the transducers horizontal at both sides. The acceptable slope is $\pm 30^\circ$.
- Do not split the paired temperature sensors; do not shorten or elongate the wiring.
- The temperature sensors should be installed on the position with stable liquid temperature; the position such as bulging segment or the bottom of the pipe should be avoided. There are two ways of installation as shown in the following pictures:

Welded jacket tube
(BRL15~40)

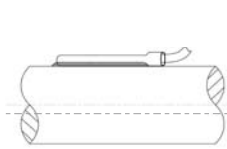

Welded socket
(BRL50~500)

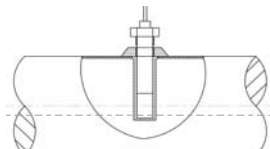

Note: the welded jacket tube type is suitable for copper pipe; the non-copper pipe installation can adopt national standard temperature sensor.

- Calculator can be fastened on the body of flowmeter, and it also can be wall-mounted separately from the flowmeter, at where is convenient for reading and operation.

Installation method

The flowmeter is generally installed on horizontal pipe. Avoid installing the flowmeter on horizontal pipes with downward outlet as there is no back-pressure on the rear side of the meter and this may cause the pipe inside to be empty.

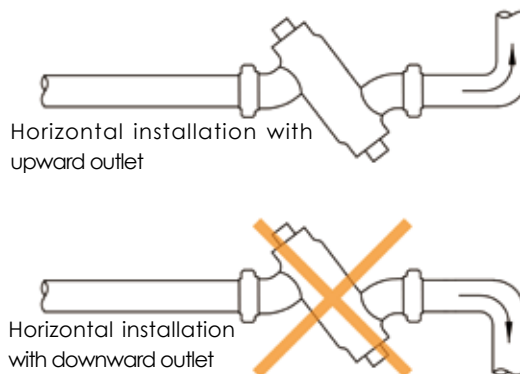

void installing on the vertical pipe with free outlet as this may result in the pipe not being full of liquid. Otherwise make sure the liquid flows upwards.

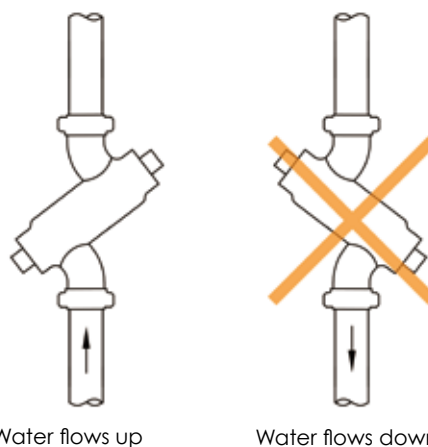

For the pipe partially loaded with liquid to be measured or with downward free outlet, the heat meter should be installed at the lowest position of the U-type pipe where is full of liquid.

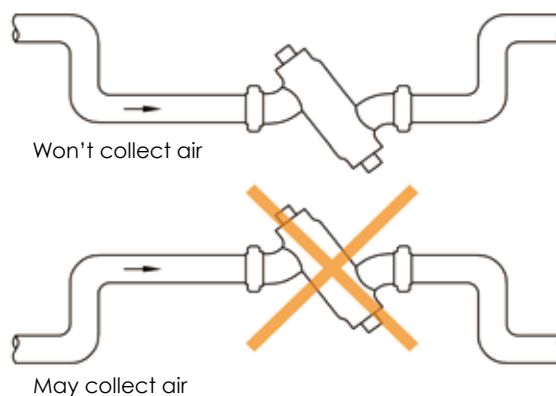

Main Components

BROAD heat meter consists of three parts: ultrasonic flow sensor, temperature sensor and calculator.

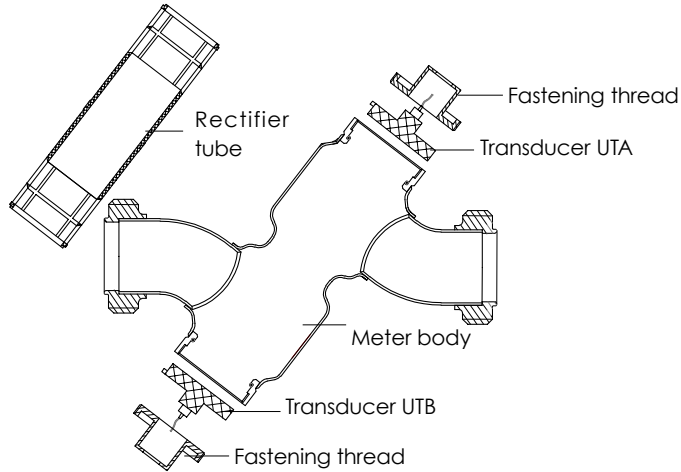

Ultrasonic flowmeter Structure (Example of BRL15-40)



Operation Panel of calculator



Braze welded tie-in: connect copper tube



Flexible tie-in: connect galvanized steel tube or other tube joint



PT 1000 temperature sensor

Spare parts list

No.	Name	Unit	Qty	Remarks
1	Ultrasonic flow sensor	Set	1	/
2	Calculator	Piece	1	The Intergraph and ultrasonic flowmeter can be separated or combined
3	Temperature sensor	Pair	1	PT100 Matching precision is higher than 0.1°C
4	Temperature sensor socket	Piece	1	To be installed on water supply pipe
5	Tie-in	Pair	1	Braze welded tie-in or flexible tie-in
6	Remote panel	Piece	1	Remote information collection (optional)
7	IC card controller	Set	1	Pre-pay management (optional)
8	Wireless module	Piece	1	Wireless BAS information collection (optional)

Communication

RS485 communication can actualize wired remote transmission, wireless remote transmission (wireless module is needed) and the communication between the remote panel and heat meter.

RS485 communication interface



Wire Type	Function
Red	Power: 3.0~6.0V
Black	Cathode
Blue	Signal A
Yellow	Signal B

Communication protocol: M-bus

Baud rate: 2400 bps/9600 bps (optional)

Cable: Shielded 4-core twisted pair cable

Max. cable length: 1500m

Contact Information

BROAD Town, Changsha,China Tel: 86-731-4086265 Zip: 410138 E-mail: gjb@broad.net

Bât A, 2ème Etage, Boîte 1001
Centre Commercial Trois Fontaines
95003 Cergy-Pontoise Cedex FRANCE
Tél : 0033 1 34 43 07 88
Fax : 0033 1 34 43 07 03

BROAD U.S.A Inc.
401 Hackensack
Ave.Suite503 Hankensack,NJ07601
Tel:001-2016783010
Fax:001-2016783011



BROAD AIR CONDITIONING
远大空调有限公司

BROAD Town , 410138 ,
Changsha , China
www.broad.com
Tel +86-731-4086688
Fax 731-4611357

Consultation
+86-731-4086265

