

BROAD X VACUUM BOILER

MODEL SELECTION & DESIGN MANUAL

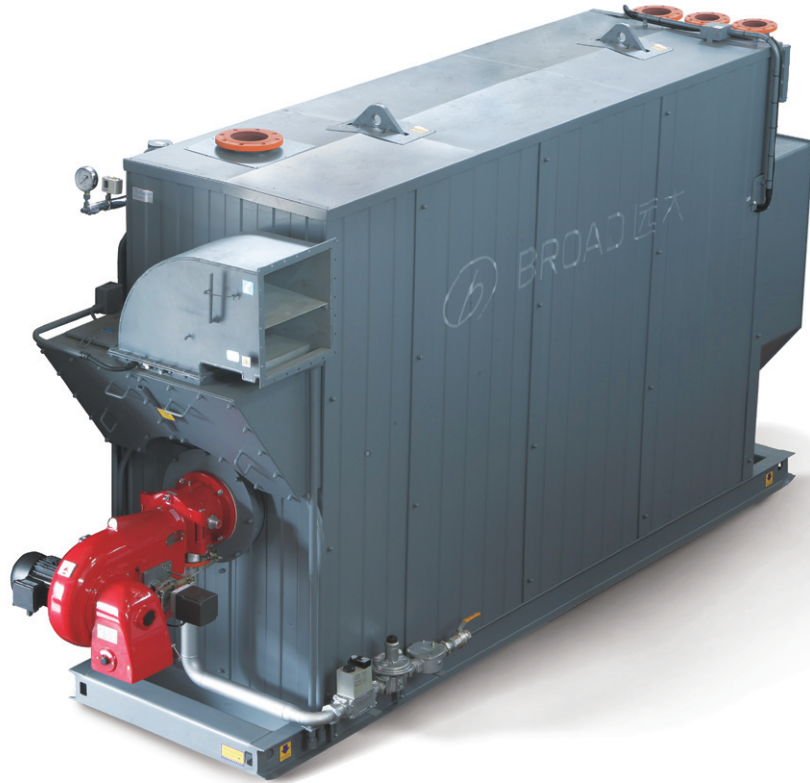

■ Function

Heating, hot water
(Dedicatedly or simultaneously)

■ Application

- Applicable for any building heating systems
- Produce hot water below 95°C

■ Heating capacity

186kW~4650kW

■ Energy sources

- Natural gas, town gas, biogas, diesel, recycled oil
- Gas/oil dual fuel

■ Absolute safe

- Negative pressure operating, never explode
- Free from boiler safety supervision

Working Principle

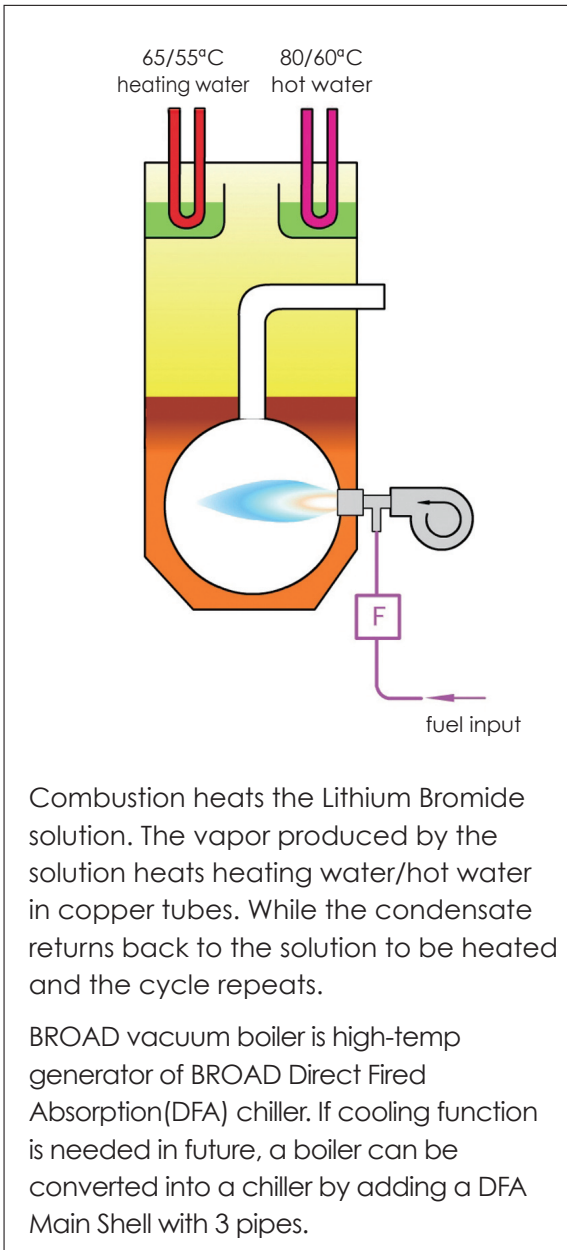

Nomenclature

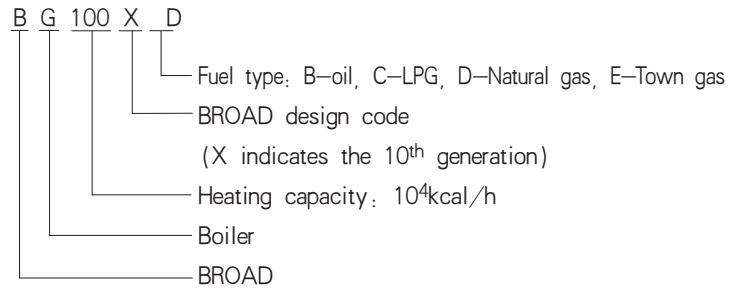

Environmental Protection Features

Operating noise dB (A)

Model	BG	16~60	80~200	≥240
Noise level dB (A)		≤57	≤58	≤60

Emissions

CO/CO₂≤0.02%, NO_x≤46ppm (O₂=5%)
 For special order with electrostatic cleaner at exhaust outlet, zero-emission can be achieved.

Performance Curve

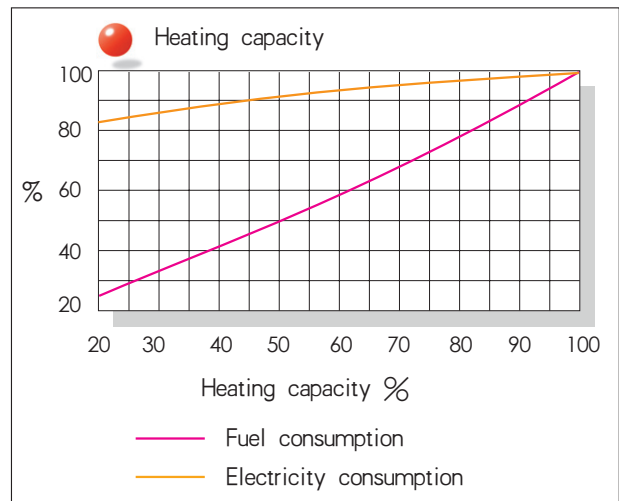

Performance Data

Model	BG	16	24	40	60	80	100	120	160	200	240	320	400
Heating capacity	kW	186	280	465	698	930	1163	1396	1861	2326	2791	3722	4650
Hot water capacity	kW	80	120	200	300	400	500	600	800	1000	1200	1600	2000
Heating water													
Flow rate	m ³ /h	16	24	40	60	80	100	120	160	200	240	320	400
Pressure drop	kPa	25	25	25	25	25	25	25	35	35	45	45	55
Connection diameter	DN	50	65	80	100	125	150	150	200	200	200	250	250
Hot water													
Flow rate	m ³ /h	3.4	5.2	8.6	12.9	17.2	21.5	25.8	34.4	43.0	51.6	68.8	86.0
Pressure drop	kPa	20	20	20	20	20	20	20	30	30	40	40	40
Connection diameter	DN	32	40	50	65	65	80	80	125	125	125	150	150
Natural gas consumption													
Heating	m ³ /h	20	30	50	75	101	126	151	201	251	302	402	503
Hot water	m ³ /h	8.5	12.8	21.4	32.0	42.7	53.5	64	85	107	128	171	214
Power demand	kW	0.4	0.4	1.5	1.5	2.7	2.7	4.6	6.6	7.6	9.1	12.1	15.1
Solution weight	†	0.5	0.8	1.1	1.3	1.7	2.0	2.4	3.0	3.6	4.2	5.4	6.4
Unit ship. weight	†	1.8	2.8	3.3	4.0	5.0	5.8	6.6	8.9	10.5	11.8	14.8	17.2
Operation weight	†	2.0	3.1	3.6	4.5	5.6	6.4	7.3	9.7	11.3	12.7	15.7	18.2

General conditions:

1. Rated heating W. output/input temp.: 65/55°C
2. Rated hot W. output/input temp.: 80/60°C
3. Highest permitted outlet temp. for heating W./hot W.: 95°C
4. Natural gas consumption is calculated upon heating value 10kWh/m³ (8600kcal/m³)
5. Pressure limit for heating W./hot W. : 0.8MPa (except special order)
6. Heating capacity and hot water capacity refer to the capacity in separate operation, which is adjustable within this range
7. Standard natural gas pressure is 16~50kPa (1600~5000mmH₂O). Lower or higher pressure can be accommodated to special orders
8. Solution weight refers to 40% LiBr solution
9. Rated exhaust temperature: 145°C.
Back pressure: 1~10mmH₂O
10. Rated heating efficiency: 93%

Model Selection & Ordering

Fuel selection	<ul style="list-style-type: none"> •Applicable fuels: natural gas, town gas, LPG, biogas, diesel, or recycled oil •Natural gas and recycled oil are of priority. Applicable to gas/oil dual fuel(for special orders) •Different fuels match different burners
Load selection	Building heating load cannot be estimated, as it is more closely related to building insulation and room function than building area.
Pressure selection	<p>The standard pressure limit for heating water/hot water is 0.8MPa.</p> <ul style="list-style-type: none"> •0.81-1.2MPa system: select high pressure type. •1.21-1.6MPa system: either extra high pressure type or secondary heat exchanger, should be comprehensively evaluated. •Above 1.6MPa system: secondary heat exchanger. •Maximum: 2.4MPa
Control	<ul style="list-style-type: none"> •BROAD boiler is equipped with complete control function including remote internet monitoring. •If users have Building Management System (BMS), the BMS control interface can be selected as an option. If BMS interface is not ordered along with the boiler, it can be purchased later. •BROAD BMS is recommended for the whole building management.
Lead time	1.5~3 months
Warranty	Free warranty is to cover 12 months from commissioning or 18 months from shipment, whichever comes earlier.

Supply List

Category	Item	Remarks
Boiler	Boiler body	Include boiler shell, front/rear flue chambers, frame base, safety devices
	Water heater	For heating water and hot water
	Thermostatic valve	two pieces for heating water and hot water constant temp. control respectively
	Insulated enclosure	Enclose the overall vacuum boiler with insulation.Removable
	Burner	Include safety devices, gas train valve, filter etc.
Control system	Control cabinet	Include low voltage components, special circuit board, PLC etc.
	Touch screen	Mounted on control cabinet for operation
	Network gateway	For remote internet monitoring
	Control interface for heating water and hot water pump	Embedded in control cabinet for pumps on/off and load adjustment
Solution	Lithium Bromide solution	Include corrosion inhibitor and energy intensifier

Scope of Supply/Work

Category	Item	BROAD	Customer	Remarks
Transportation and location	Factory to port		√	BROAD can arrange transportation upon request
	Port to jobsite		√	
	Jobsite handling		√	
Electric engineering	Power supply to enclosure		√	3 phases, 5 wires
	Internet connection	√		Network cable to the enclosure is to be provided by users
	Grounding		√	Place special grounding terminal with grounding resistance $\leq 4\Omega$ near control cabinet
Construction & installation	Foundation		√	
	External piping installation		√	Include heating water pipes, hot water pipes, water make-up and drain pipes, fuel supply pipe
	Heat insulation	√		Factory-mounted
	Antifreezing		√	Water anti-freeze treatment is recommended when the ambient temp. is below 0°C
Commissioning	Jobsite commissioning	√		User provides fuel and heating load and customer should pay BROAD for commissioning
Operation & maintenance	Operator training on site	√		Optional
	Regular maintenance	√		Paid service contract can be signed after warranty period.

Dimensions

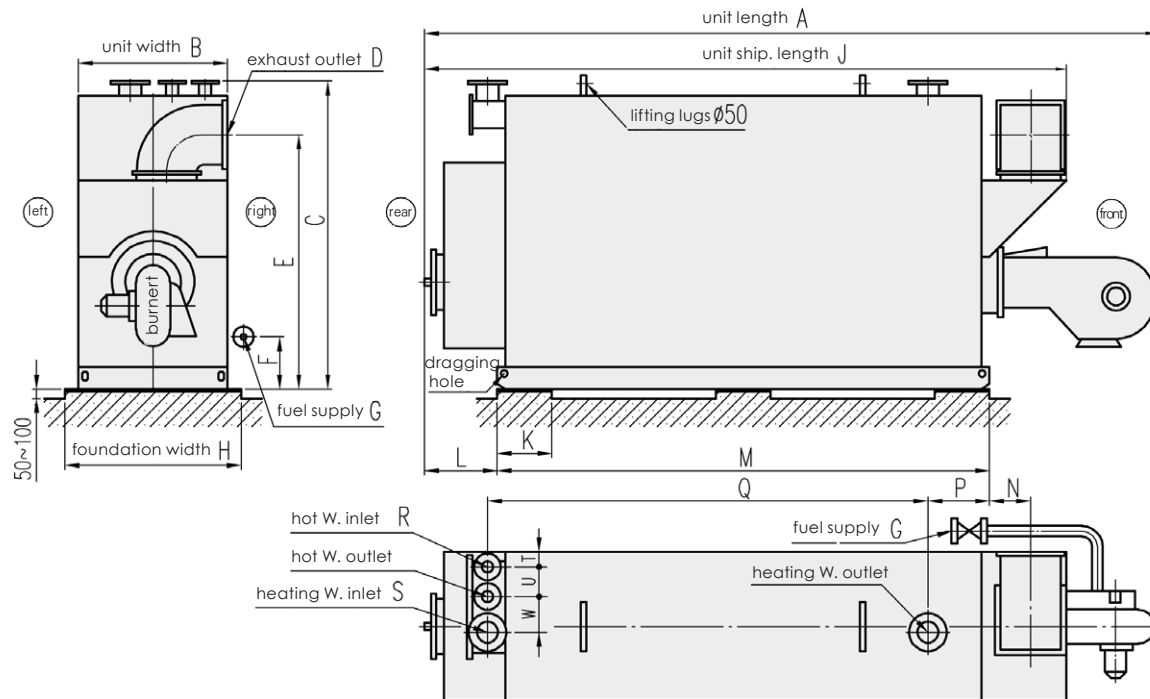

model	A	B	C	D	E	F	G	H	J	K
BG16	3050	850	2000	220×220	1850	260	DN25	950	2700	260
BG24	3550	900	2100	250×250	1950	260	DN25	1000	3200	260
BG40	4550	900	2100	250×250	1950	260	DN25	1000	4100	260
BG60	4550	1000	2200	320×320	1940	260	DN25	1100	4180	260
BG80	4600	1120	2300	350×350	2035	300	DN40	1200	4250	300
BG100	5100	1120	2300	400×400	1890	300	DN40	1200	4680	300
BG120	5150	1240	2400	440×440	2005	300	DN40	1350	4720	300
BG160	5500	1350	2650	560×560	2280	350	DN50	1450	4890	300
BG200	6200	1350	2650	560×560	2280	350	DN50	1450	5590	400
BG240	6350	1465	2800	610×610	2410	400	DN65	1550	5640	400
BG320	6400	1615	3000	710×710	2625	400	DN65	1700	5790	400
BG400	6500	1750	3150	790×790	2815	450	DN80	1850	5870	400
model	L	M	N	P	Q	R	S	T	U	W
BG16	420	1620	340	-50	1600	DN32	DN50	90	150	175
BG24	470	2120	380	-65	2130	DN40	DN65	90	180	220
BG40	470	3120	380	-65	3130	DN50	DN80	90	180	220
BG60	490	3100	380	-30	3180	DN65	DN100	90	200	225
BG80	540	3100	395	-30	3180	DN65	DN125	110	205	240
BG100	540	3600	280	450	3220	DN80	DN150	100	215	260
BG120	540	3600	300	450	3220	DN80	DN150	115	220	260
BG160	590	3600	360	435	3250	DN125	DN200	115	265	315
BG200	590	4300	360	1135	3250	DN125	DN200	115	265	315
BG240	590	4300	385	1135	3250	DN125	DN200	130	265	315
BG320	640	4300	435	1105	3300	DN150	DN250	160	305	365
BG400	640	4300	475	1105	3300	DN150	DN250	225	310	420

Note: please download the above information from www.broad.com.

Machine Room Construction Tips

Basic requirements

- Location: Vacuum boiler operates stable with little vibration and low noise. It's very convenient to select machine room: basement, ground, floor or roof can be machine room. For high-rise buildings, in order to reduce the pressure, machine room should be located at the middle of the building or on the top.
- Ventilation: Poor ventilation leads to high humidity in machine room, which may erode the boiler. Please be sure of ventilation twice min and make up combustion air. Combustion air volume for a boiler is estimated at 1.3m³ per kW fuel input.
- Drainage: 1. Boiler foundation must be on a high level in machine room. 2. All discharge pipes and drain pipes must be visible above the drainage. 3. Machine room in basement must be built above a water ditch equipped with an automatic level-controlled submerged pump.
- Temperature: Machine room temperature should be controlled within 5-43°C. Lower temperature may crack copper tubes and water box when the boiler is shut off, and higher temperature may damage electrical components. Thermometer and over temperature alarm must be installed in machine room.
- Humidity: Machine room humidity should be lower than 85%. Higher humidity may impair insulation of electrical components.
- Boiler service space

Foundation

- Please refer to dimension drawings for plinth dimensions.
- Foundation load
 - a. Machine room foundation load is recommended as 1.5times of boiler operation weight.
 - b. Make sure that the foundation is level without sinking or overload(for rooftop installation).
 - c. Boiler load should be evenly distributed on the contact surface between frame base rolling steel and the plinth.
- Anchor bolts
Boiler can be placed on the foundation directly without bolts (if there is a strong quake source or special anti-vibration requirement, please specify in a purchase order).

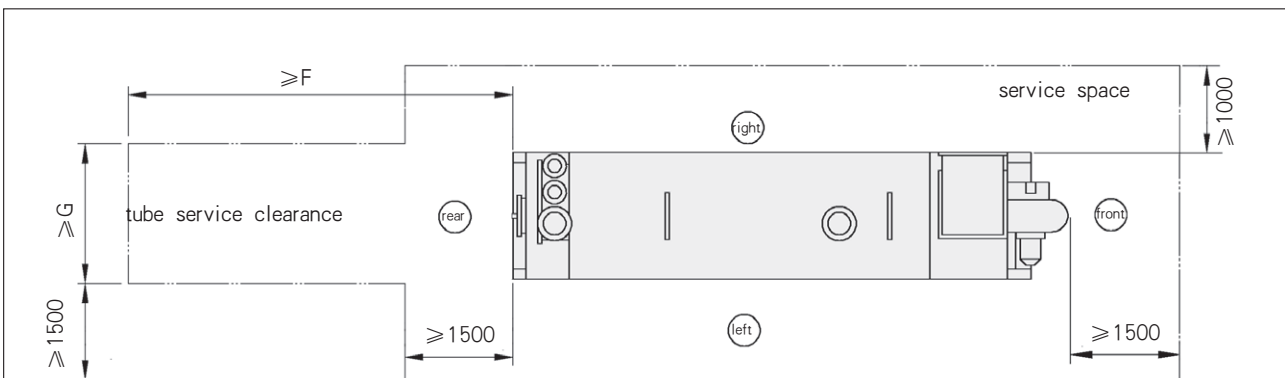

Service space

Model	16	24	40	60	80	100	120	160	200	240	320	400
F	1500	2000	3000	3000	3000	3500	3500	3500	4000	4000	4000	4000
G	600	650	650	700	800	800	900	1000	1000	1100	1250	1350

Note:

1. If machine room is smaller than the above size, please contact BROAD for a solution.
2. F, G is the tube service clearance that can use space of water pumps, doors or windows and can also be shared by 2 boilers.
3. It is recommended that the height of machine room should be 500mm higher than the boiler's.

Piping system

Gas system

- The standard pressure is 16~50kPa (1600~5000mmH₂O). Lower or higher pressure can be accommodated to special orders.
- Drain valve should be installed at the lowest part of gas pipes. All connecting pipes must be cleaned and tested for air tightness with 0.6MPa air when gas piping system is completed.
- When two or more units are connected in parallel, a buffer pipe (with diameter 3-6 times of the main pipe) must be installed at the main pipe to avoid flameout due to gas low pressure caused by simultaneous startup. Manual drain valve should be equipped at the bottom of the buffer tube.
- Customers are required to inform BROAD of the fuel type, heating value and pressure so that a burner can be properly selected and the gas pipe diameter can be notified to customers. Then customers can design filter, flow meter, ball valve, diffuser tube and pressure meter. External gas piping system is to be installed by customers at 1m distance from the burner.
- The ball valve of gas train valves must be closed if customers need to test piping pressure so that gas train valve will not be damaged by high pressure.
- A gas leakage alarm (acting value must be set 20% lower than danger value lower limit) must be equipped in machine room and be linkage controlled with draft fans. Machine room must be well ventilated all the time.

Oil system

- Oil system includes oil storage tank, oil pump, daily oil tank, oil filter and metering instruments. Oil tank should be equipped with oil check nozzle, air vent (breather valve), oil refill valve, oil level sensor and drain valve. The lowest oil level of daily oil tank must be 0.1m higher than the burner.
- Oil pipe should be copper pipe or seamless steel pipe and leakage test should be taken at 0.8MPa min.
- Medium filters are to be installed at inlet and outlet of oil storage tank. The filters should have enough section area, and should be convenient to install/uninstall and drain.
- Oil tank should be equipped with precision metering device.

Water system

- The initial filling of the heating water must be with soft water. The leakage rate should be less than 10% every year, or else large amount of city water makeup will cause water system fouling.
- In water system, zero resistance filter with section area 8-15 times larger than pipe section area instead of Y-type filters shall be used to minimize the water resistance.

- Soft connector must be installed at inlet/outlet of hot water system. The weight of the external piping system can never be borne by the vacuum boiler.
- Piping requirements: all pipes and valves should not go across the space above the vacuum boiler to avoid vacuum boiler damage caused by pipe installation, maintenance or leakage.
- Secondary heat exchange hot water system is recommended for areas with very hard water.

Exhaust system

- It is recommended independent stack be used for each vacuum boiler. If vacuum boiler has to share a common stack due to space limitation, the shared stack must be inserted type and the main stack must be bigger and higher to avoid any interference from each other. Exhaust motor valve shall be installed for each exhaust duct to avoid corrosion caused by exhaust entering into vacuum boilers that are not in operation.
- The exhaust volume is dependent on the fuel heat input. It is estimated at 1.55m³ per kW fuel input. 3-5m/s flue gas flow velocity in the stack is recommended.
- Fouling collector should be installed at flue duct inlet to the chiller to prevent condensate from flowing directly into the vacuum boiler. The indoor flue duct must be insulated. For high outdoor steel stack, insulation shall be done to maintain the up force of flue. No insulation is required for low outdoor steel exhaust stack. Try to locate the exhaust outlet as far as possible from the cooling tower, or 2m higher than the cooling tower. Otherwise the flue gas may get into cooling tower and damage the vacuum boiler.
- The rated exhaust temperature is 145°C. However, selection of insulation materials and design of fire isolation area should be based on 300°C temperature for safety concern.

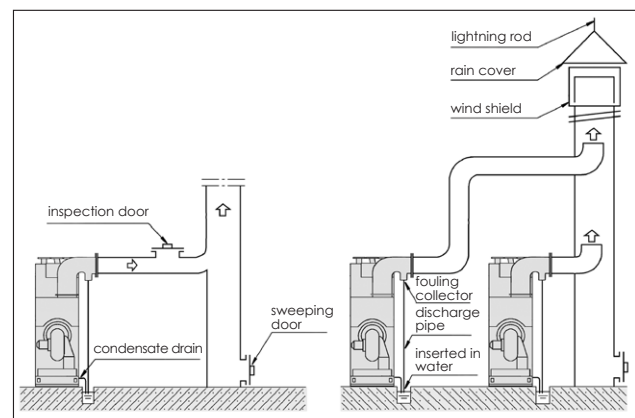

An exhaust system illustration

Control System

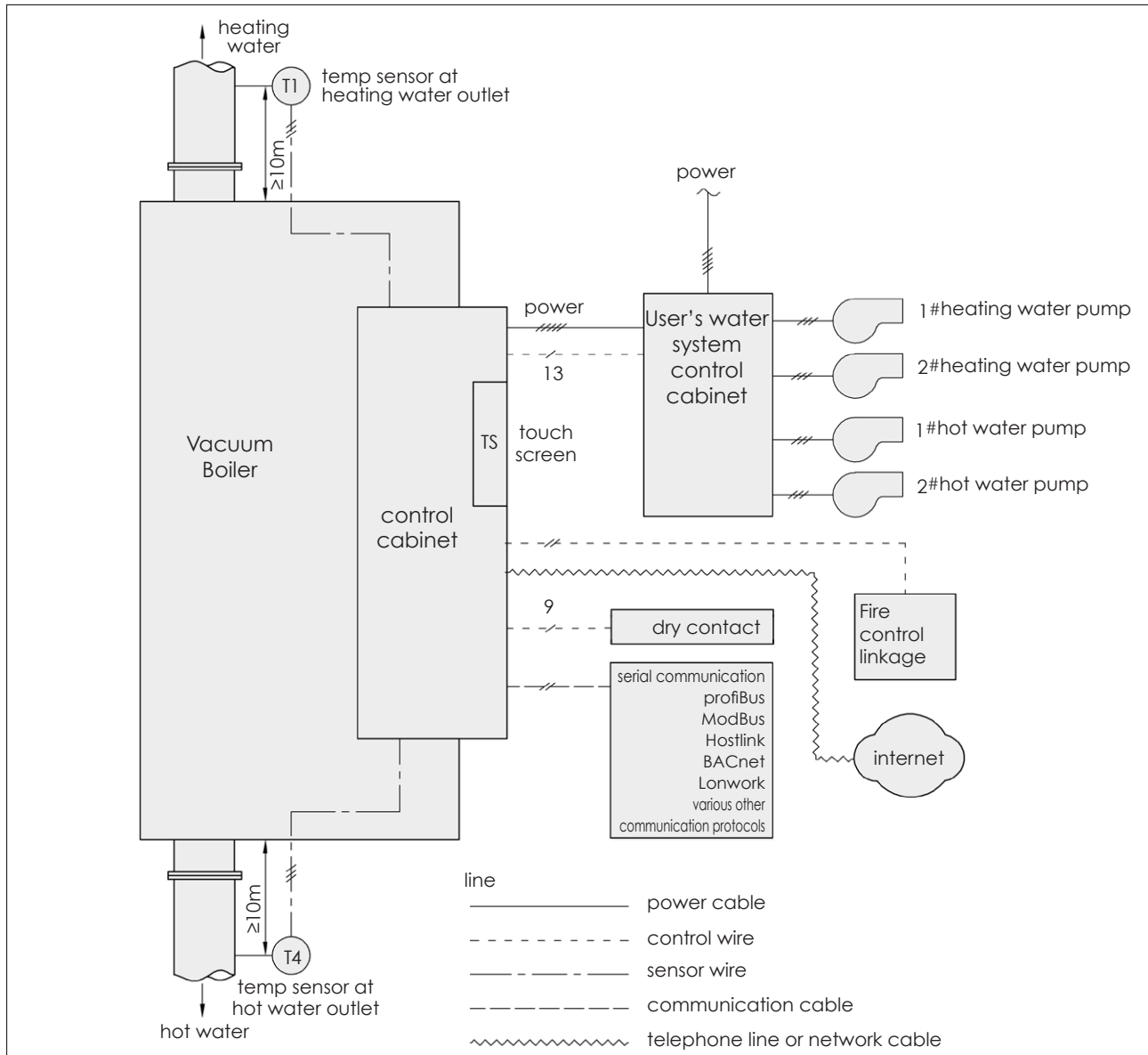

List of Control System Installation

Item	Installation position and requirement	Material	Source	BROAD scope	Customer scope
Vacuum Boiler	Control cabinet of vacuum boiler and water system; or between user's power distribution cabinets	5-core cable	customer	Wiring inside vacuum boiler control cabinet	Cable installation
Network monitoring	Vacuum boiler control cabinet	Internet cable	customer	Wiring inside vacuum boiler control cabinet	Cable installation Internet wiring
fire protection linkage	Control cabinet of vacuum boiler must follow the fire department's regulation	Fire detector 2-core cable	customer	Wiring inside vacuum boiler control cabinet	Fire detector setting Cable installation
BMS interface (optional)	Vacuum boiler control cabinet	3-core shielded cable(serial) 11-core cable(dry contact)	customer	Wiring inside vacuum boiler control cabinet	Cable installation Wiring at building side
Vacuum Boiler grounding	Between Grounding electrode and vacuum boiler, pump set connecting part, grounding resistance $\leq 4\Omega$	Grounding cable, Ground electrode	customer	/	Grounding setup, Cable installation
Heating water temp sensor, hot water temp sensor	At the heating water outlet pipe and hot water outlet pipe, 10 meters away from the vacuum boiler	Temp sensor 3-core shielded cable	BROAD	Sensor installation Sensor wiring	Sensor socket installation

Exterior Wiring Diagram

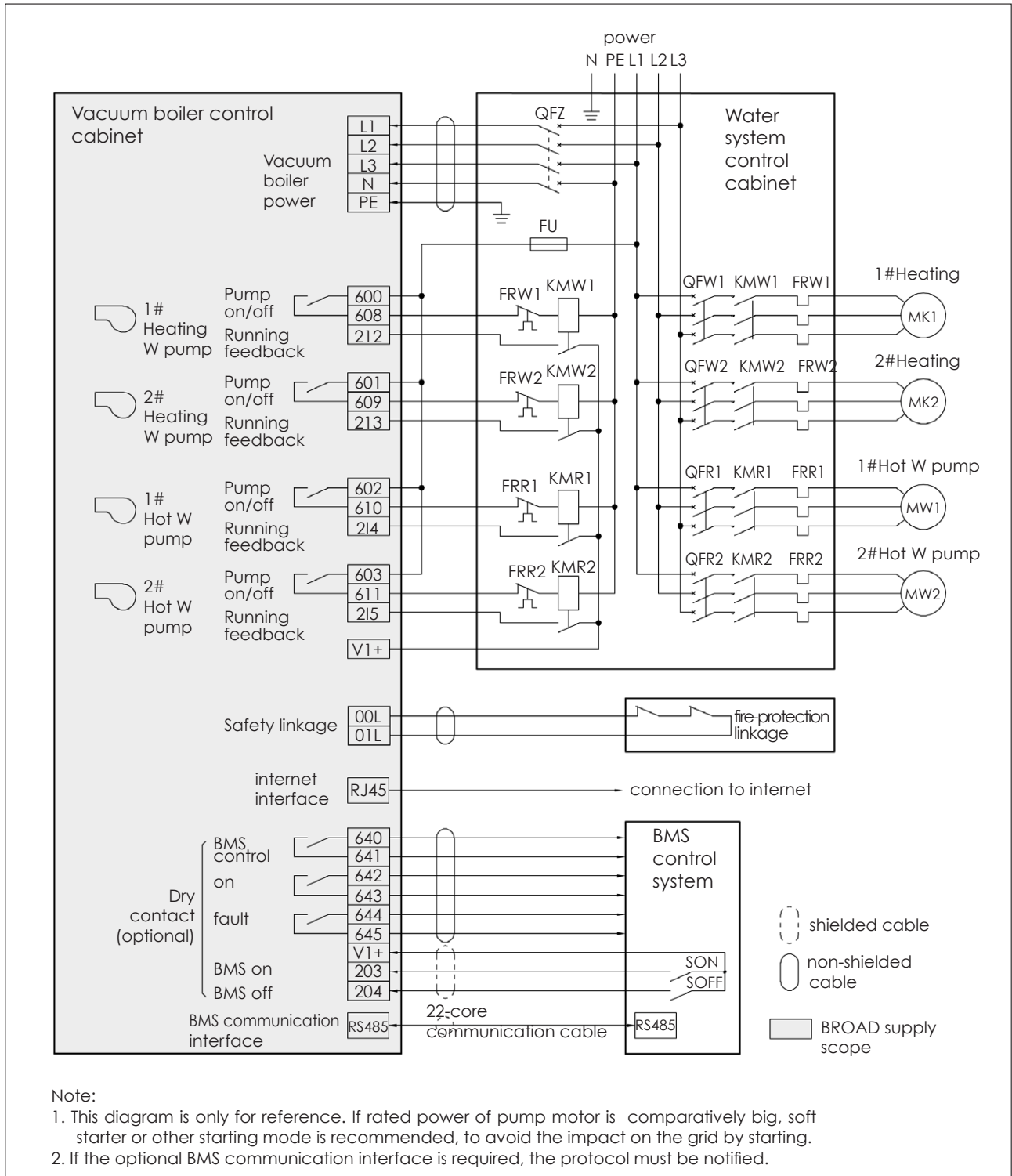

Transportation Tips

Shipping status

1. All units are to be shipped in one piece, and all of them can be containerized.
2. BROAD can arrange transportation and insurance on behalf of customers. If customers chooses to arrange by themselves, please refer to "BROAD Chiller Transportation Regulations" for container arrangement and safe transportation.

Lifting & Leveling Tips

1. Lifting must be done by qualified lifting companies that are properly insured.
2. The crane must be supported by crossties and firm foundation to prevent it from sinking. Check the crane steel ropes and hooks before lifting to prevent any accident. The lifting intersection angle must be less than 90° . It is strictly prohibited to lift the chiller with a single steel rope. When the vacuum boiler is lifted 20mm above the carriage or the ground, it should be kept for a little while. Lift the vacuum boiler slowly if everything is OK.
3. The landing of the vacuum boiler must be with care. Crash landing is strictly forbidden! As the unit is a vacuum device, any impact on the vacuum boiler is strictly forbidden.
4. When moving the vacuum boiler, only round steels or thick steel tubes can be used as rollers instead of wooden sticks. Only drag the dragging hole on the rolling steel do not place forces on other part of the vacuum boiler. Lift the unit first with jacks under the rolling steel before rigging.
5. Before the vacuum boiler is located, concrete foundation plinths must be molded and leveled. Then locate the vacuum boiler without bolts (If there is a strong vibration source or a special anti-vibration requirement, it should be stated before ordering). The pump set shall be fixed by anchor bolts. The foundation must be level and solid to make sure no sink or overload (when the unit is installed on the roof).
6. After vacuum boiler locating, please adjust leveling and lay thin steel plate where it is uneven to guarantee compact contact between the vacuum boiler and base. Take tube sheet as the leveling point and make front/rear and left/right leveling (check level height of every part by acrylic tube). It should be leveled within 0.8/1000 both lengthwise and sidewise. Leveling must be done within 2 hours after locating the vacuum boiler, otherwise the vacuum boiler base will be damaged.
7. The vacuum boiler must be located levelly and its steel frame bases must match the plinth, the weight of the vacuum boiler must be evenly balanced on the plinth. Otherwise, the vacuum boiler may be twisted slowly, which will finally result in damage due to leakage.
8. The vacuum boiler should be protected by full time personnel during transportation & installation. No access to the vacuum boiler or valves for unauthorized persons. Valves of the vacuum boiler are forbidden to be screwed. If the machine room is under construction, protective measures are needed to avoid damage or dirt to the vacuum boiler. Do not scrape the paint or insulation layer.

Lifting sketch

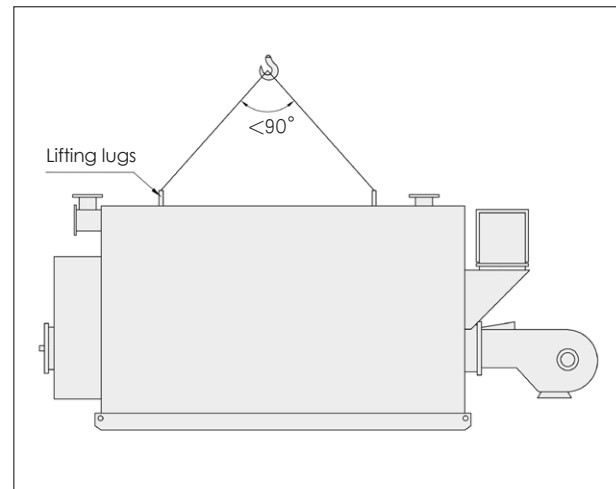

Leveling Sketch

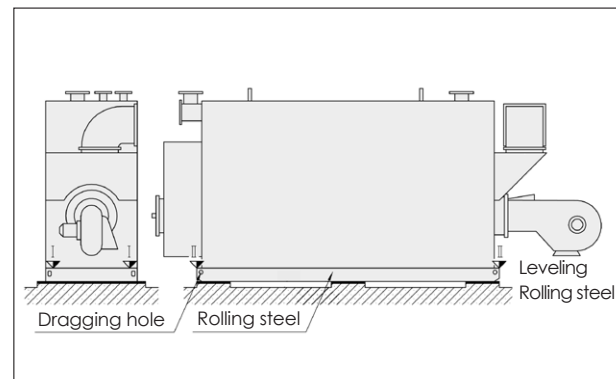

Foundation sketch

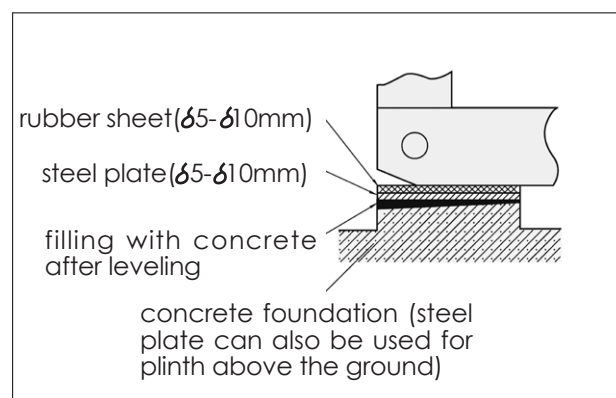

Contact:

BROAD Town, Changsha

Tel:0086-731-84086688

Fax:0086-731-84610087

Zip:410138

www.broad.com



BROAD vacuum boiler has obtained all certification of ISO, CE, ETL and other international certification.



BROAD AIR CONDITIONING
远大空调有限公司

BROAD Town Zip 410138 www.broad.com Tel 0731-84086688 Fax 4610087

Note: BROAD pursues a policy of continuous product perfection. Catalog information is subject to changes without notice.

